

Actively Biased Differential Drive Rectifier circuit with Backscattering Communication

Asma Mahar^{1*}, Ayesha Hassan², Naveed³, Arham Iqbal⁴, Madiha Azhar⁵, Yasir⁶,
Arsalan Jawed⁷

^{1,2,3,6,7}PAF-KIET (Karachi Institute of Economics and Technology), Korangi Creek, Karachi, 75190, Pakistan,
(asmamahar@pafkiet.edu.pk, ayesha.hassan@pafkiet.edu.pk, Naveed.21@pafkiet.edu.pk, yasir@pafkiet.edu.pk,
arsalan.jawed@pafkiet.edu.pk)

^{4,5} Department of Electronic Engineering, NED University of Engineering and Technology,
Karachi, 75290, Pakistan (arhamiqbal@neduet.edu.pk, madiha_azhar@hotmail.com)

Abstract: A differential drive rectifier with active bias mechanism to reduce diode device losses has been presented in this paper. Unlike the conventional and static V_{th} cancellation technique rectifiers, this configuration achieves power loss reduction in both forward and reverse biased conditions. The decrease in turn on voltage in forward bias condition, along with decrease in reverse leakage current during reverse bias condition has been achieved, hence achieving more than double efficiency. Under same input conditions (coupling coefficient ' k '=0.1 at 200MHz frequency with transmitter and receiver inductance of 22nH), actively biased differential drive rectifier was able to achieve DC voltage of 1.56V for 10k Ω load resistance in contrast to 950mV generated by full bridge rectifier. Besides being more efficient than other rectifiers, it provides regulated output DC voltage under variable coupling conditions. Backscattering communication has been performed using varactor by changing the resonance frequency of the receiver, the WPT efficiency degradation was noted to be only 7% for 200mV backscattering data amplitude.

Keywords: WPT (Wireless power transfer), backscattering, resonant circuit.

I. INTRODUCTION

The curiosity for development of smart devices and internet of things has given rise to an increasing demand for energy harvesting. Devices capable of generating sufficient power using various sources of energy, where bulky batteries cannot be afforded, has become a trend for years. Great development in energy scavenging through solar energy, vibrational energy or kinetic energy to power up devices has been perceived. But for short distance applications, electromagnetic (EM) scavenging has gained a lot of attention. EM scavenging is known for its highly efficient power link but at the same time, the coupling variations are quite unpredictable, which reduces the AC-DC conversion efficiency.

While striving for high WPT efficiency, receiving circuitry efficiency is taken into account along with the rectifier conversion efficiency. To ensure sufficient wireless power transfer through EM coupling, coupling coefficient ' k ' is estimated prior to the circuit design. ' k ' for a certain application is determined by the transmitted power, inductor Q factor and distance between coils. To maximize the signal reception at receiving end, high Q inductor design has been proposed in [1]. [2] suggests an improved resonator with better transmission efficiency in contrast to spiral and helical resonators occupying same volume. Another design methodology integrating rectifier with the

antenna (rectenna) for incident power as low as 5-100uW/cm² has been presented in [3].

To generate sufficient power for the device, an efficient receiving circuit is accompanied by a high AC-DC rectifier conversion efficiency. Most of the time, ' k ' is kept constant and AC-DC conversion is improved by optimizing the rectifier design.

In conventional rectifier circuits, the maximum achievable efficiency is limited by switching losses. To reduce losses, use of optimal waveforms other than a constant envelope signal has been reported in [4]. The time varying envelope signals namely, multi-tone, white noise, and chaotic signals have high PAPR (peak to average power ratio). Compared to a single tone signal with same average power, these signals are capable of activating the rectifying devices for a lower average input power level.

In [5], the rectifier's efficiency for variable load or coupling conditions has been maintained by adding configurability to the rectifier design. In weak coupling conditions, the operating mode changes to a voltage doubler to maintain desired output voltage level whereas, it works as a full bridge rectifier in strong coupling condition. Hence the decrease in DC level is being compensated by a more efficient circuit in weak input power conditions.

In this paper, a four stage differential Dickinson's rectifier has been presented. Considering constant coupling and loading conditions, the improvement in

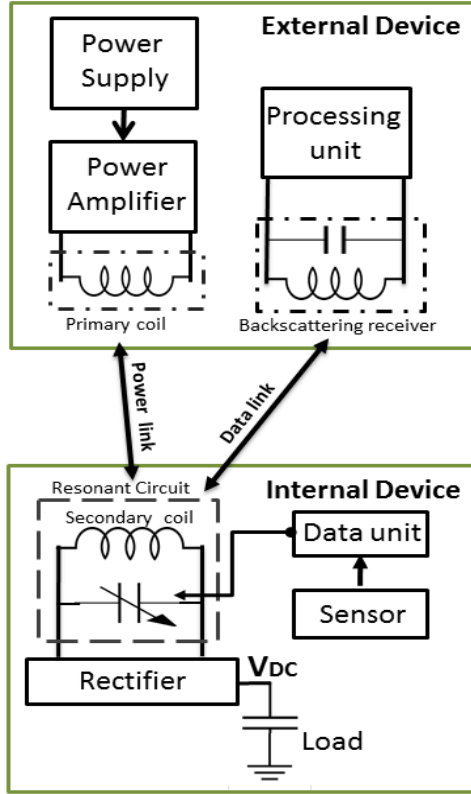

Figure 1: Inductive Wireless Power Transfer system block diagram

rectifier's efficiency has been focused. The differential drive rectifier proposed in [6] has been used. It has active bias mechanism which results in low R_{on} and low reverse leakage current, which results in a better conversion efficiency.

In addition to the forward power link, most of these applications require a reverse data link to acquire information on an external device for processing. The data is sent back on a wireless communication channel using the same on-chip receiver coil. Immense research has been carried out recently to avoid the degradation of power efficiency due to conventional backscattering techniques [8]. This will be discussed later in section III.

A complete pictorial representation of WPT system along with backscattering communication is shown in fig.1. It has an external device and an internal device. The power is transferred through coupling among primary and secondary coil. The primary coil when driven by the power amplifier, generates AC magnetic fluxes. This variable flux couples to the secondary coil and produces an AC signal at the receiving end.

Received AC signal is rectified to power up device. Most often this dc signal is also processed to send back desired output voltage inside the chip. If the device has

sensor in it, and sensor data is required externally, then it is sent instead of DC encoded signal over the backscattering channel. Sensor data proper reception on receiving end, also ensures the required power generation.

For backscattering communication, varactor or a switch is connected in parallel to the receiver circuit to vary the peak voltage at data frequency. This data is received externally on a separate coil resonating at frequency of backscattered data. The frequency of data is kept below the WPT frequency to keep the efficiency degradation of WPT minimum. This data is processed to extract required information.

The paper is organized as follows: Section II describes the rectifier circuit with its active bias mechanism and simulation results. Section III discusses the backscattering technique and its effect on WPT efficiency. Finally, conclusion is given in section IV.

II. DIFFERENTIAL DRIVE CMOS RECTIFIER CIRCUIT

The power conversion efficiency of a rectifier circuit is dependent upon the forward and reverse biased power loss of the diode connected devices. Where forward power loss is due to the turn on voltage of the device and reverse power loss is due to leakage current. Power conversion efficiency (PCE) of rectifier is defined as,

$$PCE = \frac{P_{out}}{P_{in}} \quad (1)$$

Where, P_{out} and P_{in} represents output and input power respectively, and

$$P_{in} = P_{out} + P_{rectloss} \quad (2)$$

$P_{rectloss}$ represents power loss across rectifier, which is a multiple of number of diode devices 'N'. Single diode power loss represented by P_{diode} is the summation of power loss in forward biased (P_{fwd}) and reverse biased (P_{rev}) direction.

$$P_{rectloss} = N * P_{diode} \quad (3)$$

And,

$$P_{diode} = P_{fwd} + P_{rev} \quad (4)$$

Schottky diodes have been widely used for PCE improvement because of low turn on voltage of 200-300mV. But due to high fabrication cost, diode connected MOSFETs have gained preference over them. Several techniques have been proposed to increase efficiency of MOS diodes. V_{th} cancellation techniques have been employed to greatly improve the PCE by achieving low ON resistance [7].

The static V_{th} cancellation techniques constantly provides V_{th} at the gate and source of the transistor, irrespective of the instantaneous input AC signal

amplitude. This helps achieve very small forward bias resistance but also increases the reverse leakage current. In ref [7] and [8], an active bias mechanism has been proposed which automatically reduces reverse leakage current by increasing V_{th} in reverse biased condition while keeping V_{th} low during forward bias condition. This active mechanism achieves double the efficiency as compared to static V_{th} cancellation.

The rectifier is a cross coupled configuration driven by a differential input signal as shown in fig. 2. The WPT frequency is 200MHz. When V_{ac+} has its positive cycle, V_{ac-} is negative hence reducing the turn on voltage. Similarly, when V_{ac+} gets negative, V_{ac-} is positive, hence increasing V_{th} in the reverse biased condition.

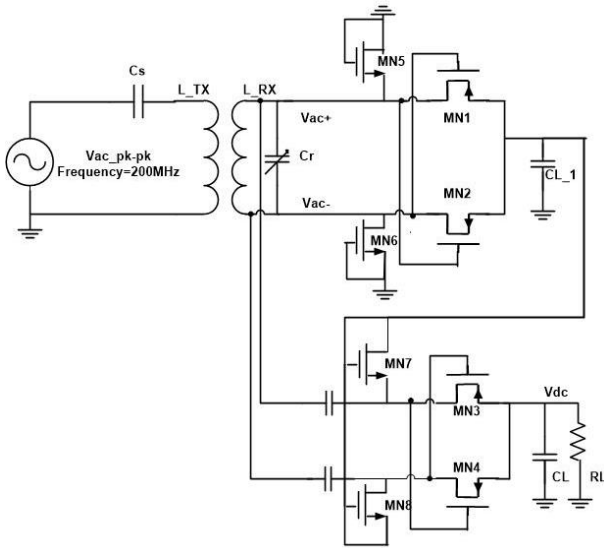

Figure 2: Differential Drive Rectifier circuit

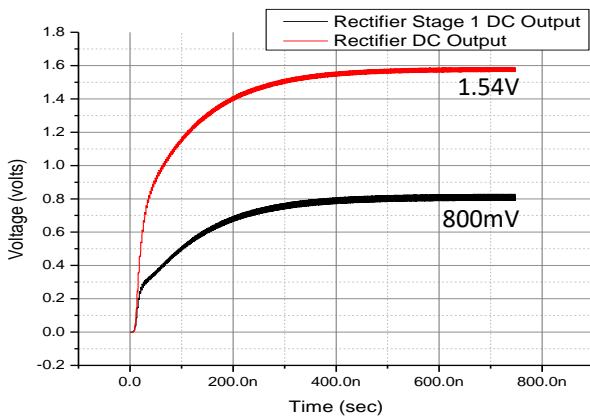

Figure 3: Voltage at output of stage 1 and stage 2

The stage is copied twice with first stage providing bias voltage to the second stage, shown in fig 3. This is known as self V_{th} cancellation as the rectifier itself is providing the required bias voltage.

Fig 4 shows a conventional full bridge rectifier. Fig 5 shows the DC voltage generate by the conventional

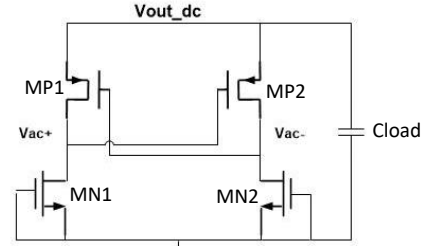

Figure 4: Conventional Full Bridge Rectifier circuit

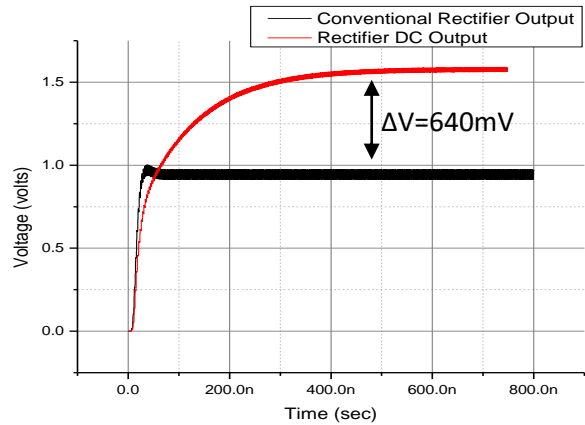

Figure 5: DC voltage generated by conventional full bridge rectifier and differential drive rectifier

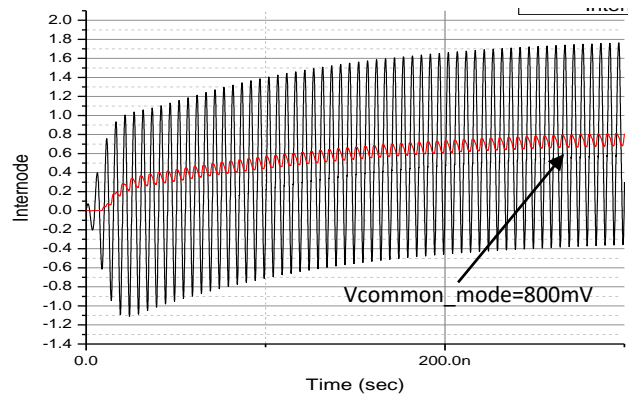

Figure 6: Gate bias voltage for stage 2

rectifier and the differential drive rectifier. The increase in efficiency is noticeable. For the same input 1.2Vpk voltage, the dc generated by differential drive rectifier is 1.56V, whereas, conventional rectifier has only 950mV dc output.

Fig 6 shows the voltage at intermediate node (input voltage to stage 2) of differential drive rectifier. As this signal is the gate bias voltage for second stage of rectifier, it improves the efficiency of second/output stage of rectifier. If the coupling gets stronger, the dc offset of this signal increases for next stage along with high input signal. This decreases the efficiency, ultimately resulting in regulated dc voltage at the output. The decrease in efficiency occurs due to large leakage current with large bias voltage. This has been shown in fig 7. By

increasing the input AC signal amplitude from 1.2Vpk to 2.25Vpk, the DC voltage has increased from 1.56V to 1.64V only, which is only 4.8% increase in response to a signal that is twice larger than the previous case.

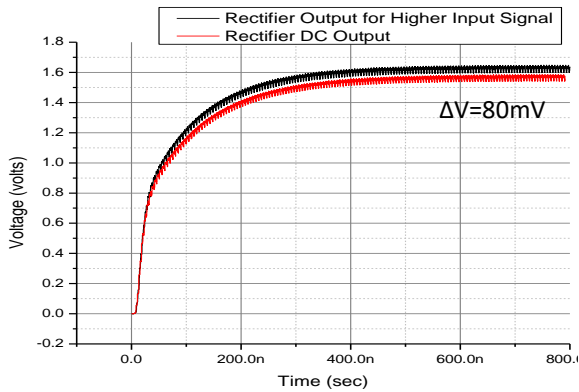

Figure 7: DC voltage generated for $V_{acpk}=1.2V$ and $V_{acpk}=2.25V$

Another interesting feature of this rectifier circuit is that if the first and second stage n and p MOS devices are properly matched, the intermediate stage capacitor can be removed or a small capacitor could be sufficient to reduce the voltage ripple. This is because the forward current of nMOS can be sunk by the pMOS and vice versa.

Also, multiple stages of this rectifier can be used to further improve the output dc voltage according to the requirement. But as this circuit works on self-bias mechanism, the input voltage should be sufficient enough to provide V_{th} to the first stage devices to start functioning.

III. BACKSCATTERING COMMUNICATION

Conventional backscattering employs a switch in parallel with the receiver coil. The amplitude of the received signal is varied by switching it ON for either '1' or '0' of the data, while keeping it OFF for the other. The ON resistance is usually kept sufficient enough to obtain backscattering signal amplitude of 200-250mV. This is shown in fig 8. Instead of a switch, the resonant frequency can also be changed by using varactor (fig 9), this effects the transmission efficiency. The change in resonance frequency from the WPT frequency of the receiver results in a low receiving efficiency. In either of the cases, the load of the receiver coil has been changed.

The main concern of this paper is that the efficiency of WPT should be least effected by backscattering. Data rate is kept quite low as compared to WPT frequency, but the dc for both '1' and '0' of the data should be sufficient enough to meet the requirements of the device.

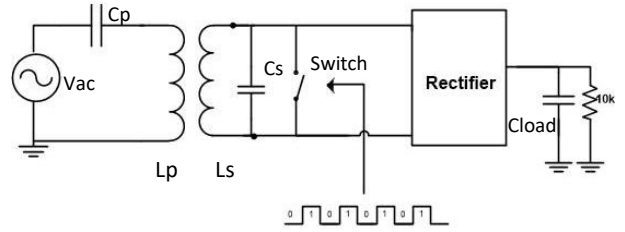

Figure 8: Conventional backscattering technique

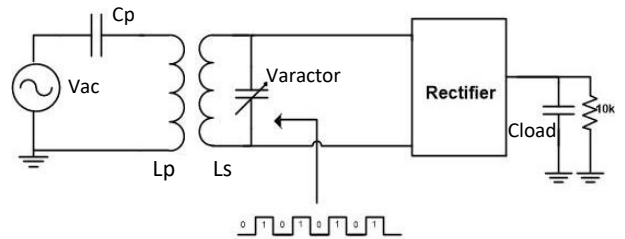

Figure 9: Backscattering using varactor

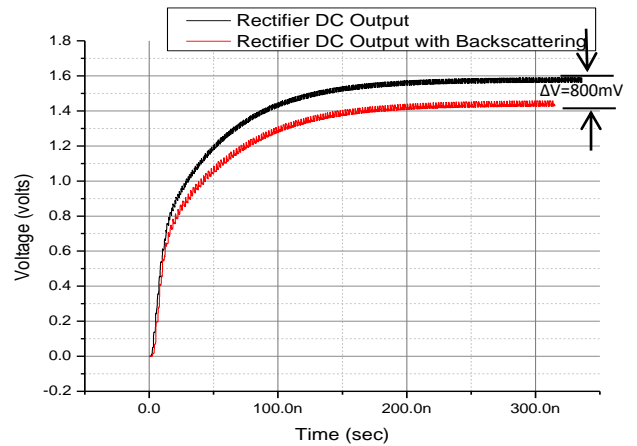

Figure 10: Output of rectifier with and without backscattering

Fig. 10 shows the change in V_{dc} for 1.2Vpk and 1Vpk-pk AC signal. The change in dc level was observed to be only 110mV, i.e. DC voltage changed from 1.56V to 1.45V. Hence concluding the compatibility of the rectifier to be used for backscattering without effecting WPT efficiency considerably.

IV. CONCLUSION

A differential drive rectifier with active V_{th} cancellation technique has been presented. The output DC voltage generated is 1.56V in contrast to 950mV generated by a conventional full bridge rectifier. The efficiency improvement is considerable. Along with high efficiency, circuit shows a self-regulated output DC voltage for different coupling conditions. Which adds robustness to the design.

Backscattering using varactor by changing the resonance frequency of the receiver has been shown. For a 200mV backscattered data, DC change of only 110mV was observed, effecting WPT efficiency by only 7%.

REFERENCES

- [1] Chia-Chu Wu, Hung-Wei Chiu, Da-Sheng Lee, Min-Hsiang Chang, Chien-Chi Lu, and Chao-Ning Chang, "High Q Inductor Design Using Modified Magnetic Substrate Structure", *IEEE International Conference on Wireless Power Transfer*, pp 284-287, May 2014.
- [2] Wei Wei, Yoshihiro Kawahara and Tohru Asami, "Experimental Analysis of Double Spiral Resonator for Wireless Power Transmission", *IEEE transaction*, pp 9-12, 2013.
- [3] Zoya Popovic, "Far-Field Wireless Power Delivery and Power Management for Low-Power Sensors", *IEEE transaction*, pp 1-4, 2013.
- [4] A. Collado, and A. Georgiadis, "Optimal Waveforms for Wireless Power Transfer", *IEEE transaction on Microwave and Wireless Components Letters*, Vol. 24, No. 5, May 2014.
- [5] Hyung-Min Lee and Maysam Ghovanloo, "An Adaptive Reconfigurable Active Voltage Doubler/Rectifier for Extended-Range Inductive Power Transmission", *IEEE Transactions On Circuits and Systems*, Vol. 59, No. 8, August 2012.
- [6] K. Kotani, A. Sasaki, and T. Ito, "High-efficiency differential-drive CMOS rectifier for UHF RFIDs," *IEEE J. Solid-State Circuits*, vol. 44, no. 11, pp. 3011–3018, Nov. 2009.
- [7] K. Kotani and T. Ito, "Self-V_{th}-cancellation high-efficiency CMOS rectifier circuit for UHF RFIDs," *IEICE Trans. Electron.*, vol. E92-C no. 1, pp. 153–160, Jan. 2009
- [8] A. Sasaki, K. Kotani, and T. Ito, "Differential-drive CMOS rectifier for UHF RFIDs with 66% PCE at -12 dBm input," in *Proc. IEEE ASSCC*, pp. 105–108, Nov. 2008.
- [9] Bo Zhao, Nai-Chung Kuo, *IEEE*, and Ali M. Niknejad, "An Inductive-Coupling Blocker Rejection Technique for Miniature RFID Tag", *IEEE Transactions On Circuits and Systems*, Vol. 63, No. 8, August 2016.